

MATLAB/Simulink-based Dynamic Simulation Toolbox for New Generation Power System

Lin S., Xiong Y., Yao W., Ai X., Wen J.

Beijing Institute of Technology, Beijing, China

ABSTRACT

The crystal characteristics of the diamond samples that are synthesized by several dynamic loading methods, i.e., explosion and impact, have been characterized by XRD and TEM and compared with the diamonds synthesized by static high-temperature and high-pressure method. The crystal lattice integrity of the diamonds synthesized by the dynamic loading methods is poor, and the diamonds possess the characteristic of polycrystalline coalescence. Similar to the static diamonds, the diamonds synthesized by the methods of plane shock wave and detonation products are also single cubic crystal, while the diamonds synthesized by the methods of axial symmetry shock wave and direct detonation have different proportions of cubic and hexagonal crystal structures. The reasons for the formation of these properties have been studied by analyzing the synthesis process and technical characteristics. The results are helpful for the reasonable application of these diamond products, and also have some significance in deepening the understanding of the synthesis mechanism of different dynamic loading methods.

1. INTRODUCTION

The dynamic loading method is the kind of method using explosion and impact to synthesize diamonds, in which formation thermodynamics, dynamic conditions, and characteristics of the product are similar to each other. It is also called the dynamic pressure method, relative to the static high-temperature and high-pressure methods (static method) [1, 2]. It includes the plane shock wave method (flyer plate method)[3, 4], i.e., a flying plate driven by the explosive shocks to the graphite to synthesize diamonds; an axial symmetry shock wave method (driver tube method) [5, 6] in which the explosive circumferential compress graphite and metal powder in the metal tube to synthesize the diamond; direct detonation method [7, 8, 9] of adding the graphite into high explosive and initiating explosive to synthesize the diamond; and the method of detonating products [10, 11, 12] in which the negative oxygen balance explosives directly detonate to synthesize the diamond. These four methods are typical dynamic loading methods of synthesizing diamond in the world. In recent years, people have paid attention to these methods because the corresponding diamond products are widely used in LED, LCD, optical communication, and other new technologies of precision machining. Several kinds of diamond on the basic properties of morphology, particle size distribution, grain size, and crystal types have different characteristics. The differences in crystal types have direct influences on their basic properties and application. This paper analyzed the crystal

structure of the diamonds to find the qualitative and quantitative differences of the characteristics between them and to analyze the relationship between the crystal properties and the explosion and impact conditions when combined with experimental conditions.

2. MECHANISM AND SYNTHESIS CONDITIONS OF THE SAMPLE OF FOUR DYNAMIC LOADING METHODS

2.1. Flyer plate method

The mechanism of the synthesis is that the flyer, which is driven by high speed and pressure shock waves produced by the explosive shocks the graphite target, and the graphite target immediately take on high temperature and pressure that caused by the kinetic energy of the high-speed flyer in the process. In this situation, the graphite crystal structure transforms into diamond. The basic structure of the synthesis equipment is illustrated in Fig.1.

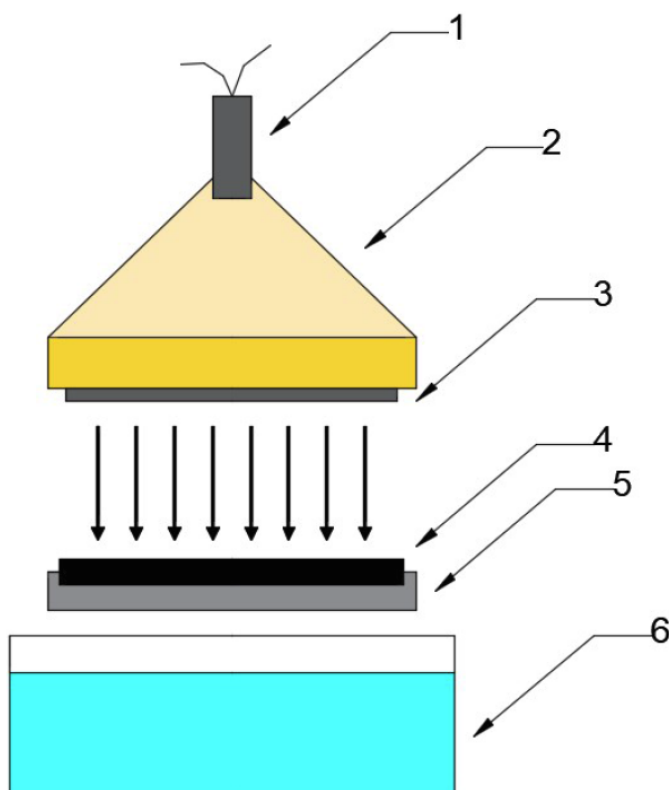

Fig.1 Schematic diagram of flyer plate method (1, detonator; 2, plane wave generator and standard high explosive; 3, metal plate; 4, graphite plate; 5, support plate; and 6, water pool)

The main compositions are Composition B (TNT, 40%; RDX, 60%), carbon steel plate with thickness ranging from 3mm to 5mm, industrial detonator no.8, and high-purity graphite. The explosive needs to be shaped as a plane wave generator to ensure the shock wave oriented

impact on the metal plate. The component elements for explosion and shock are placed on the pool to rapidly cool and conveniently reclaim the explosion product. The non-diamond impurities are removed from the product by chemical purification, and the diamond powder is obtained. Normally, the method is used in an open-type outdoor environment, and the closed type is suitable only for sample research in a laboratory.

The sample characterized in this paper was obtained under the followed conditions: composition B size: $\text{Ø}45\text{mm}\times 12\text{mm}$, casted; carbon steel plate size: $45\text{mm}\times 45\text{mm}\times 3\text{mm}$; graphite plate size: $\text{Ø}40\text{mm}\times 8\text{mm}$.

2.2. Driver tube method

The mechanism of the method is that the graphite, catalyst, and metal powders are placed into the steel tube sealing by following some proportional relations; the steel tube is surrounded by ammonium nitrate explosive or TNT. The charge is initiated from one end; in the detonation process, the explosive applies circumferential compression. In this case, the condition of high temperature and pressure in the steel tube is formed and the graphite transforms into diamond. Then, the steel tube is reclaimed and cut to obtain the product in the tube; the diamond can be obtained after chemical purification. The structure of the charge is illustrated in Fig.2. The industrial production of the method usually requires a large amount of explosive which can up to 100 tons. Thus, the production is conducted in an open field or mountain away from people. The study sample can be obtained by reducing the explosive equivalent to the laboratory permissible level.

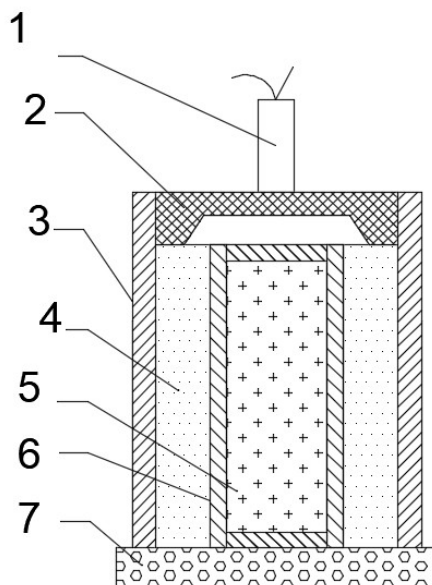

Fig.1 Charge structure of the driver tube method (1, detonator; 2, plane wave generator; 3, steel tube; 4, explosive; 5, graphite and metal powder; 6, sample plug; 7, dynamic energy absorption pad)

The sample characterized in this paper was obtained under the followed conditions: raw materials: graphite and copper powder; sample tube size: $\text{Ø}10\text{mm}\times 60\text{mm}$, 2.5mm thickness; driver tube size: $\text{Ø}20\text{mm}\times 65\text{mm}$, 3mm thickness; explosive size: $\text{Ø}40\text{mm}\times 70\text{mm}$; explosive components: RDX/ binder=5/2.

2.3. Direct detonation method

The process of the method is to proportionally mix the graphite and explosive, such as hexogen (RDX), octogen (HMX), TNT-RDX-Al explosive and TATB, and shape the mixture to charge. The charge is initiated to detonation synthesis in the protective medium, and the product is chemically purified. The schematic diagram of this method is illustrated in Fig.3. The method is usually applied in indoor hermetic chambers and has less influence on the environment.

The sample characterized in this paper was obtained under the followed conditions: charge composition: RDX/graphite=90/10; charge weight: 430g; charge size: $\text{Ø}60\text{mm}$; cylinder; compacted.

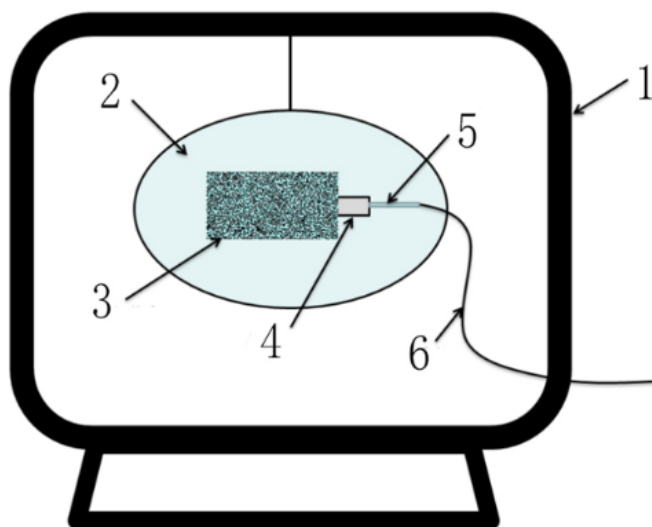

Fig.3 Schematic diagram of direct detonation method (1, explosion chamber; 2, water; 3, charge; 4, booster charge; 5, detonator; 6, wire)

2.4. Detonation product method

The synthetic method uses the rest of the carbon of the negative oxygen balance explosives in the detonation reaction as carbon source; an additional carbon source is not needed. Under the thermodynamic and kinetic conditions created by detonation, the carbon transforms to diamond through the process of decomposition, coalescence, phase transformation, and crystallization. The schematic diagram of this method is illustrated in Fig.4. The generated diamond consists of the nanoparticles with narrow particle size distribution. The size of 90% particle in weight is less than 20 nm with a shape that is spherical or near spherical. Similar to the direct detonation method, the detonation product method is also suitable for indoor experiment or production in airtight container.

The sample characterized in this paper was obtained under the followed conditions: charge composition: TNT/RDX=60/40; charge weight: 200g; charge size: Ø22mm; cylinder casted.

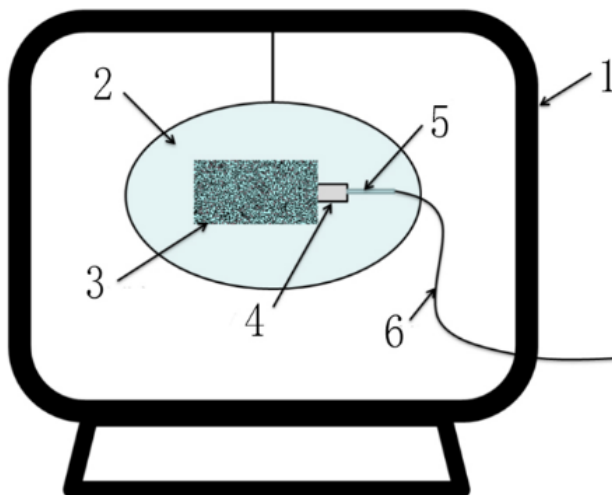
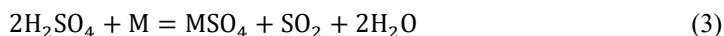
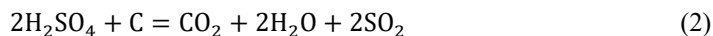
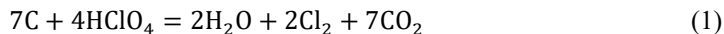

Fig.4 Schematic diagram of detonation product method (1, explosion chamber; 2, water; 3, charge; 4, booster charge; 5, detonator; 6, wire)

2.5. Chemical purification and post-processing of synthetic products

The primary product obtained through various dynamic loading methods is a mixture containing a large amount of impurities, mainly including graphite (including the raw material that does not transform into diamond, the graphite caused by the carbon crystal from the explosive, and a certain amount of graphitized diamond), amorphous carbon, metal fines (from catalyst, shell and wires of detonator, container exfoliation, and explosion component), residues of assembly material and protective medium, and others. As these impurities mainly exist in the nano- or microscales, the proportion that can be removed physically is very low. Therefore, purification mainly depends on the oxidation reaction. The commonly used oxidizing agents include perchloric acid, concentrated sulfuric acid, concentrated nitric acid, potassium permanganate, potassium dichromate, hydrogen peroxide, and so on. In this study, the concentrated sulfuric and perchloric acid joint oxidation is used. The principle of reactive purification is expressed as follows (C represents graphite and amorphous carbon, and M (suppose the valence of M is positive bivalent, M^{2+}) represents metal impurities):



3. SYNTHETIC DIAMOND CRYSTAL CHARACTERISTICS

One of the common characteristics of the diamond synthesized by explosion and impact methods is small granularity, which belongs to the micro powder category in the midst of synthetic diamond products. X-ray diffraction (XRD) and electron microscope analysis methods are mainly used to analyze the characteristics of the diamond crystal. XRD mainly analyzes the characteristic parameters of crystal, such as the type of crystal structure, surface spacing, and grain size. Transmission electron microscopy (TEM) is further observed and analyzed in the structural characteristics of crystal. Instrument model, parameters, and test conditions of the experimental equipment used are as follows: X-ray diffractometer: German, Bruker D8 ADVANCE, fitting limits: 10° to 99.997° , step size: 0.02° ; Transmission electron microscopy: American, FEI Tecnai G2F30, accelerating voltage: 300 KV.

3.1. Diamond synthesized by flyer plate technique

3.1.1. X-ray diffraction analysis

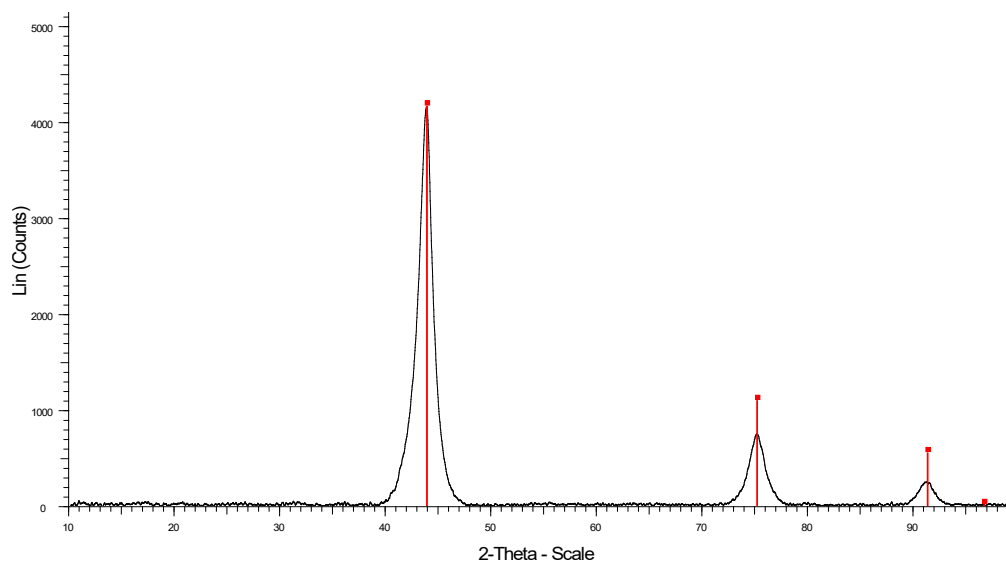

Fig. 5 XRD pattern of diamond synthesized by flyer plate method

Fig. 5 shows that the diffraction peaks appear in the diffraction angle $2\theta=43.9^{\circ}$, 75.3° , and 91.4° , respectively. Compared with the diamond standard card (JCP: 03-065-6329), the characteristic diffraction peak of the cubic diamond corresponds to (111), (220), and (311) crystal plane, respectively. The specific diffraction data and the lattice parameters are shown in Table 1.

Table 1 XRD data of the diamond synthesized by flyer plate method

Intensity, %	Diffraction angle $2\theta/^\circ$	Diffraction intensity Count	Surface spacing $d/\text{\AA}$	Corresponding to crystal surface	Crystallite size (Scherrer): 102.3 \AA	Space group: $Fd\bar{3}m (227)$
100.0	43.929	4181	2.05943	(111)	FWHM(30): 0.795° system: cubic	cell param.: $a:3.56699$ JCP: 03-065-6329
18.0	75.307	754	1.26095	(220)		
6.1	91.434	254	1.07599	(311)		

3.1.2. TEM analysis

Fig.6 clearly shows three rings corresponding to the three lattice planes of the cubic diamond, respectively, which shows that the samples are polycrystalline aggregate particles, and the dispersed bright spots on the circle indicate the existence of large grains.

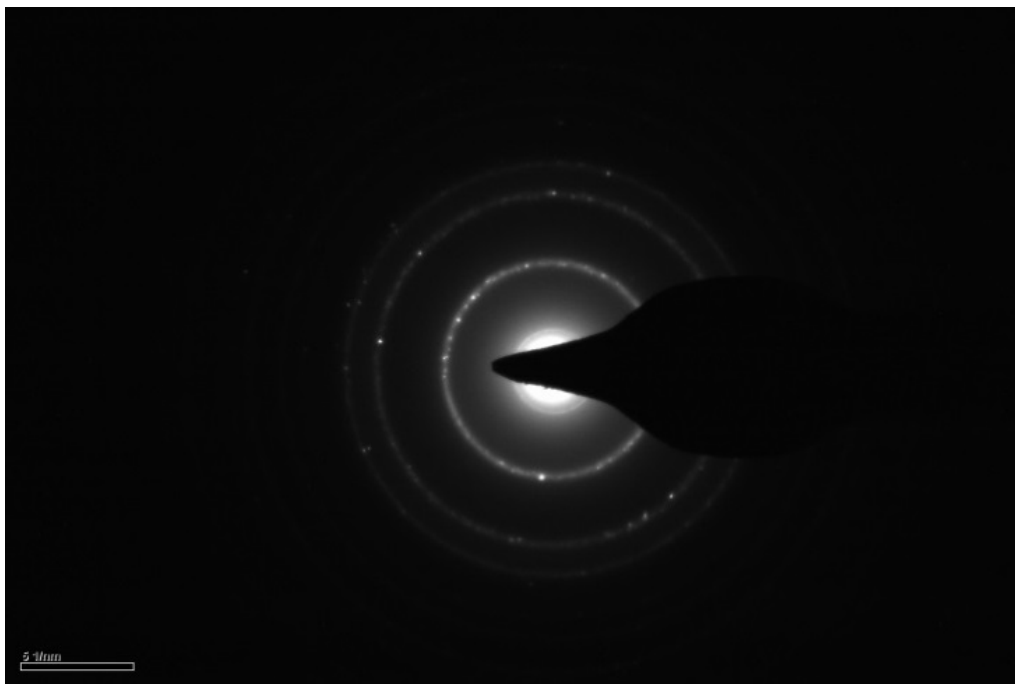

Fig. 6 TEM photo of diamond synthesized by flyer plate method

3.2. Diamond synthesized by driver tube method

3.2.1. X-ray diffraction analysis

Fig.7 shows that four diffraction peaks appear in the diffraction angle $2\theta=42.0^\circ$, 43.9° , 75.3° , and 91.4° , respectively. Compared with the diamond standard card (JCP: 03-065-6329, indicated by the red line in the figure), the three diffraction peaks are the characteristic diffraction peaks of the cubic diamond corresponding to (111), (220), and (311) crystal planes, respectively. Compared with the hexagonal diamond standard card (JCP: 00-050-1083,

indicated by the blue line in the figure), five diffraction peaks in the figure are consistent with the main characteristic peaks of this card. Except for the first diffraction peak at the diffraction angle 2θ of 42.0° , the remaining three characteristic peaks coincide with the cubic diamond, respectively. However, the diffraction intensity is lower. The five characteristic peaks correspond to (011), (006), (018), and (116) crystal planes of the hexagonal diamond. The specific diffraction data and lattice parameters are shown in Table 2.

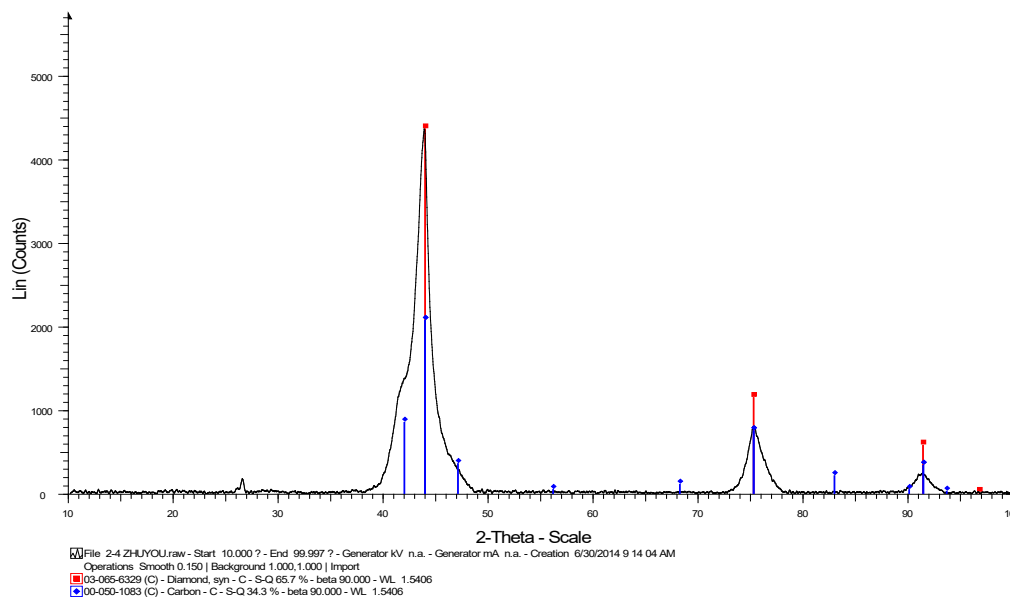

Fig. 7 XRD pattern of diamond synthesized by driver tube method

Table 2 XRD data of diamond synthesized by driver tube method

Intensity, %	Angle 2-Theta	Intensity Count	d value Angstrom	JCP:03-065-6329	JCP:00-050-1083
31.3	41.970	1356	2.15091	FWHM(30): 2.39°	FWHM(30): 1.64°
100	43.868	4336	2.06216	Crystallite Size	Crystallite Size
18.4	75.328	799	1.26066	(Scherrer): 34.1 Å	(Scherrer):49.7 Å
5.4	91.386	235	1.07643	System: cubic	System: Hexagonal
				Space group: Fd-3m (227)	Space group: P63/mmc (194)
				Cell param.: Initial-Final a: 3.56699-Fixed	Cell param.: Initial-Final a: 2.52210-Fixed c: 12.35570-Fixed

3.2.2. TEM analysis

Besides showing the three clear rings, Fig.8 also shows the three unclear rings, which means that the diamond sample is not a single cubic diamond. Combined with the analysis in Fig.7, our findings indicate that the diamond sample has a hexagonal structure; therefore, the diamond has both the characteristics of polycrystalline gathering and the property of

polycrystalline types coexisting. The dispersed bright spots on the circle are brighter and denser than those in Fig.6, which means that the larger grain exists in the sample and the grain size distribution range is wide.

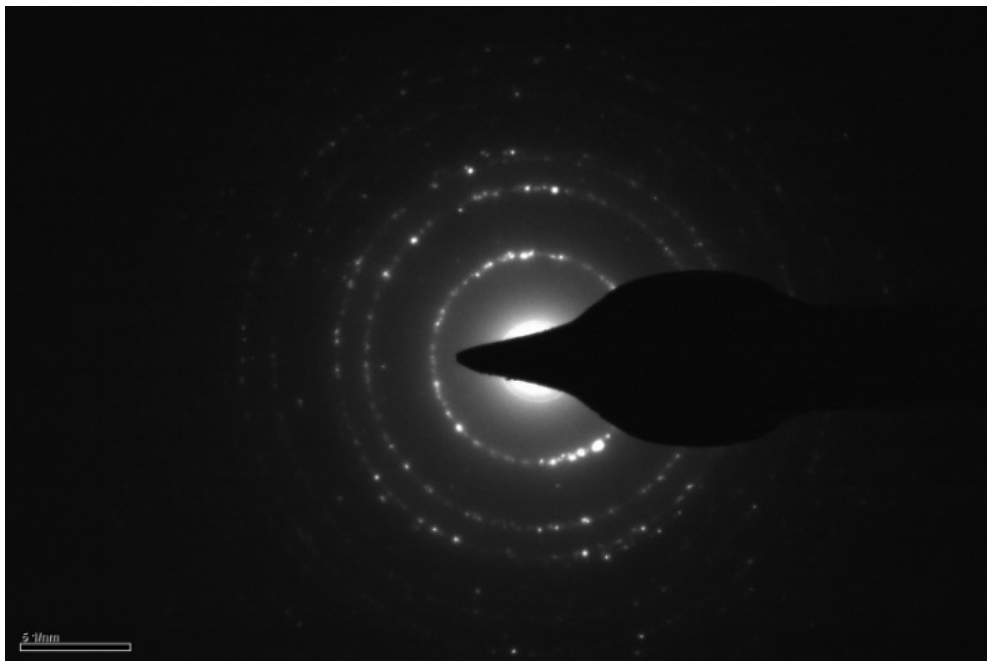

Fig. 8 TEM photo of diamond synthesized by driver tube method

3.3. Diamond synthesized by direct detonation method

3.3.1. X-ray diffraction analysis

The diffraction spectrum and diffraction data are observed in Fig.9 and Table 3, respectively. Four diffraction peaks appear in the diffraction angle $2\theta=42.0^\circ$, 43.9° , 75.3° , and 91.4° , respectively. Compared with the diamond standard card (JCP: 03-065-6329, red line in the

Table 3 XRD data of diamond synthesized by direct detonation method

Intensity, %	Angle 2-Theta	Intensity Count	d value Angstrom	JCP:03-065-6329	JCP:00-050-1083
100.0	43.929	7162	2.05943	FWHM(30): 1°	FWHM(30): 0.745°
18.7	75.307	1342	1.26095	Crystallite Size (Scherrer): 81.3 \AA	Crystallite Size (Scherrer): 109.2 \AA
5.9	91.434	425	1.07599	System: Cubic	System: Hexagonal
16.5	42.032	1183	2.14790	Space group: Fd-3m (227)	Space group: P63/mmc (194)
				Cell param.: Initial-Final	Cell param.: Initial-Final
				a: 3.56699-Fixed	a: 2.52210-Fixed
					c: 12.35570-Fixed

figure; JCP: 00-050-1083, blue line in the figure), the result is similar to that in Fig. 7. The proportions of hexagonal diamond, diffraction data, and lattice parameters have certain differences. However, they have significant differences in grain size compared with the former. The cubic and hexagonal diamond grain sizes of the latter increase by 138.4% and 119.7%, respectively; and the proportion of the hexagonal diamond decreases from 34.3% to 26.9%.

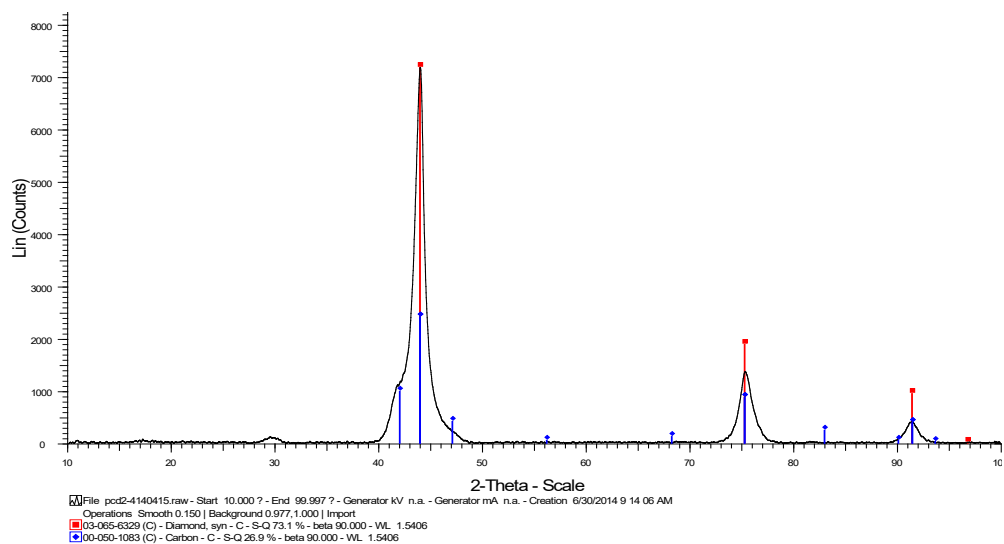

Fig. 9 XRD pattern of diamond synthesized by direct detonation method

3.3.2. TEM analysis

Fig.10 shows three relatively clear continuous rings. Without more rings such as those in Fig.8, only three diffraction rings corresponding to the crystal plane exist, for the hexagonal diamond content may be decreased so that the crystallinity of diamond crystals is higher and the grain size is more uniform.

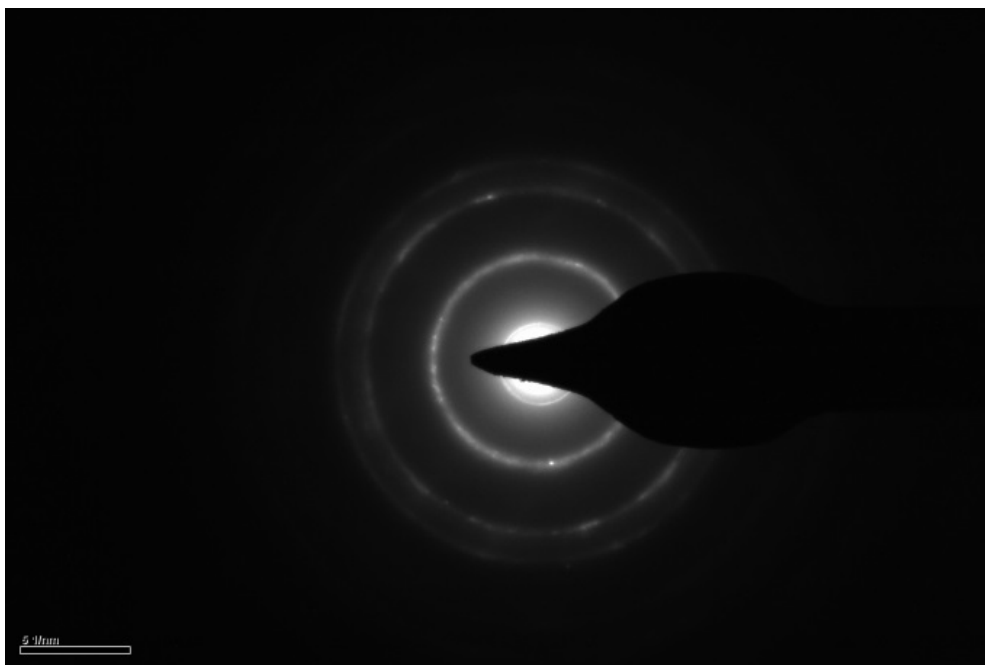

Fig. 10 TEM photo of diamond synthesized by direct detonation method

3.4. Diamond synthesized by method of detonation products

3.4.1. X-ray diffraction analysis

Comparing the diffraction spectrum in Fig.11 and the diffraction data in Table 4 with that in Fig.5 and Table 1, the similarity of the features of the two crystals is very high; both are single cubic diamond, and the grain size differences are 102.3 Å and 50.4 Å, respectively, which affects their granularity distribution and aggregation.

Table 4 XRD data of diamond synthesized by detonation product method

Intensity, %	Diffraction angle $2\theta/^\circ$	Diffraction intensity Count	Surface spacing $d/\text{Å}$	Crystallite size (Scherrer): 50.4 Å	Space group: Fd-3m (227)
100.0	43.656	5896	2.07169	FWHM(30): 1.61°	Cell param.: Initial-Final a: 3.56699-Fixed
14.5	75.048	855	1.26467	System: Cubic	JCP:03-065-6329
5.7	91.327	334	1.07697		

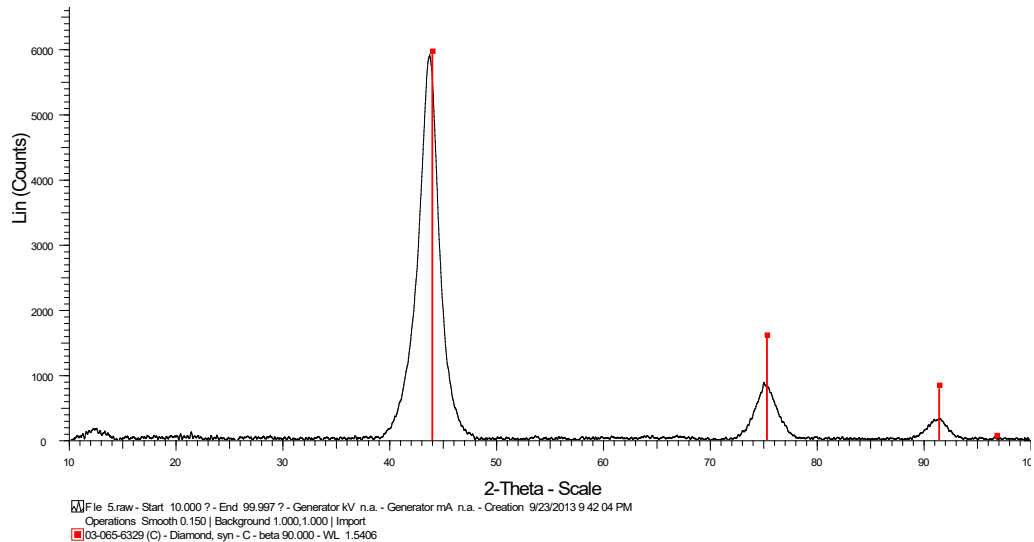

Fig. 11 XRD pattern of diamond synthesized by detonation product method

3.4.2. TEM analysis

Fig.12 shows three clear continuous rings corresponding to three crystal planes of the cubic diamond; every ring is bright and continuous, without obvious spots and virtual halo, which shows that the crystallinity of the sample is good and grain size distribution is concentrated.

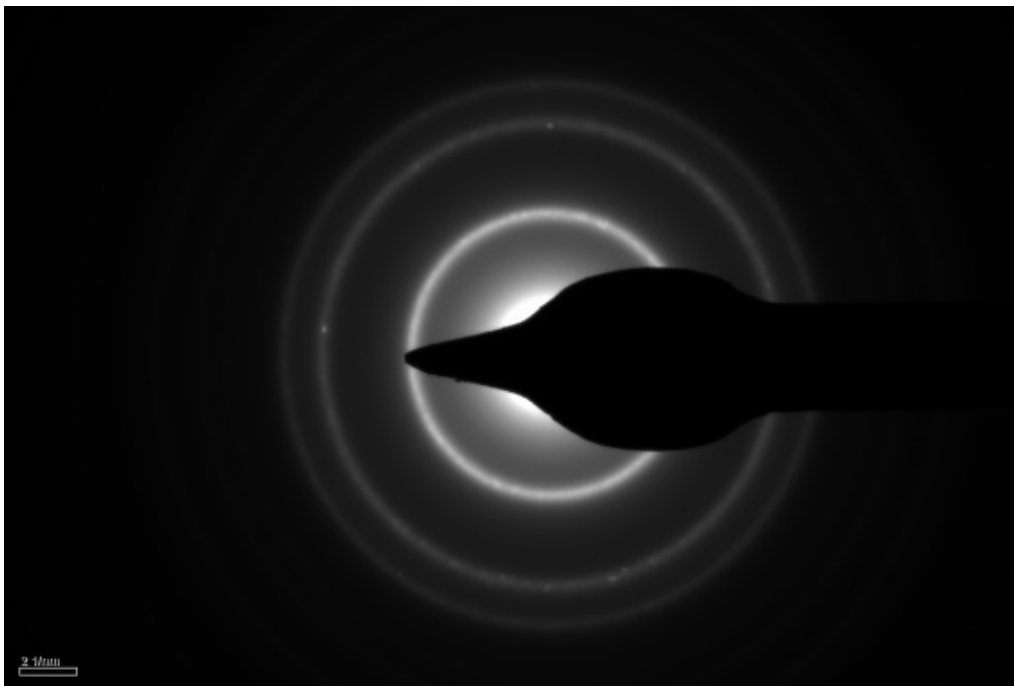

Fig. 12 TEM photo of diamond synthesized by detonation product method

3.5. Monocrystalline diamond synthesized by static method

To compare the crystal characteristics of diamonds synthesized by the dynamic loading method with those synthesized by the static method, the XRD and TEM results of 0.125 μm diamond powder are presented. All the test equipment and conditions used are the same as those for the diamond synthesized by the dynamic loading method involved in this study.

3.5.1. X-ray diffraction analysis

The diffraction spectrum and diffraction data are observed in Fig.13 and Table 5, respectively. Three diffraction peaks appeared in the diffraction angle $2\theta = 43.9^\circ$, 75.2° , and 91.4° , respectively. Compared with the diamond standard card (JCP: 03-065-6329, blue line in the figure), the characteristic diffraction peaks of the cubic diamond, correspond to (111), (220), and (311) crystal planes, respectively. It can be concluded that the lattice of the diamond samples is more completed from the diffraction peak's sharp shape and slightly broadened.

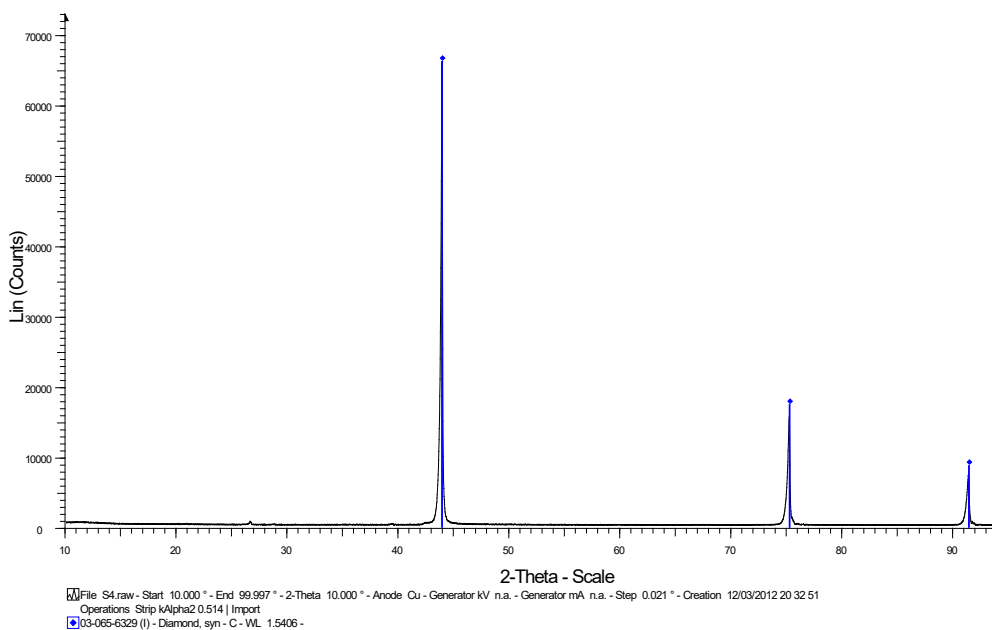

Fig. 13 XRD pattern of diamond synthesized by static method

Table 5 XRD data of diamond synthesized by static method

Intensity, %	Diffraction angle $2\theta/^\circ$	Diffraction intensity Count	Surface spacing $d/\text{\AA}$	Crystallite size (Scherrer): 872.7 \AA	Space group: $Fd\bar{3}m (227)$
100.0	43.878	56579	2.06172	FWHM(30): 0.0932°	Cell param.: Initial-Final a: 3.56699-Fixed
22.8	75.203	12920	1.26244	System: Cubic	JCP:03-065-6329
11.9	91.389	6719	1.07640		

3.5.2. TEM analysis

Fig.14 clearly shows the diamond lattice, which is a typical characteristic of the monocrystalline diamond.



Fig. 14 TEM photo of diamond synthesized by static method

4. DISCUSSION AND CONCLUSION

1. From the XRD spectra of the diamond synthesized by several dynamic loading methods, the characteristic diffraction peaks have all been obviously broadened. This is the typical characteristic of the nano- and micro- particle materials, which shows that the lattice is incomplete, the crystal has inclusions, stress, or is defective. It is due to the instantaneity of explosion and impact synthesis process. In the extreme non-equilibrium process, the atoms don't have enough time to crystallize, neither the martensite phase transformation in situ nor the diffusive phase transition.
2. The diffraction peak intensity of static diamond is 8 to 13 times that of the diamond synthesized by the dynamic loading method (strongest peak (111) surface, for example), which means that the former samples have numerous crystals, which strictly meet the conditions of Bragg diffraction, and also proves that the latter samples have a smaller number of regular diamond crystals.
3. According to the TEM photos of the samples, the dark field diffraction patterns of the diamonds synthesized by the dynamic loading methods are diffraction rings corresponding to the crystal plane, which are the characteristics of the gathering of the polycrystalline, while the static diamond is the typical single crystal lattice.
4. The diamonds synthesized by flying plate and detonation products methods only have a single cubic-diamond crystal structure. The grain size of the former (102.3 Å) is significantly larger than that of the latter (50.4 Å), which is associated with the phase transformation mechanism and the loading duration; the former is transformed from the good crystallization flake graphite in situ phase transformation under the shock wave condition, while the latter is aggregated by carbon atoms or molecular fragments because of explosive decomposition; the flyer's shock wave action time is about 10 μs and the detonation process is only 0.5 μs.

5. Diamonds synthesized by the driver tube method and direct detonation method both have cubic and hexagonal diamond lattices. For the thermodynamics and kinetics conditions provided by these two methods are non-uniform, they satisfy the conditions for the formation both of cubic and hexagonal crystal diamonds.
6. According to the XRD results of diamonds synthesized by driver tube method and direct detonation method, the diffraction peak broadening of the former is larger than that of the latter. The grain sizes of both the cubic diamond and the main crystal components are 34.1 Å and 81.3Å, respectively. The difference of this feature will directly affect the cutting function when these diamonds are used for precision grinding material.

In conclusion, by testing the characteristics of diamonds synthesized by several dynamic loading methods and comparing these diamonds with the static diamond, we qualitatively and quantitatively analyzed and summarized the common and unique characteristics of these types of diamonds, and the relationship between the characteristics and the corresponding formation conditions. The results have certain reference values for further research on the crystal characteristics, synthesis mechanism, and application of diamonds synthesized by various dynamic loading methods.

REFERENCES

- [1] F. P. Bundy, H. T. Hall, H. M. Strong, et al., Man-made diamond. *Nature*, 1955.176 (4471): p.51-55.
- [2] H. T. Hall, Utah, H. M. Strong , et al., Method of making diamond, US patent 2947610A,1960.
- [3] P. S. Decarli, J. C. Jamieson. Formation of diamond by explosive shock.*Science*, 133(3467), pp.1821-22, 1961.
- [4] P. S. DeCarli, M.P.Calif., Method of making diamond, US patent 3238019A,1966.
- [5] Trueb, L.F. Microstructural study of diamonds synthesized under conditions of high temperature and moderate explosive shock pressure. *Journal of Applied Physics*, 42(2), pp. 503-10, 1971.
- [6] A.S. Balchan, G. R. Cowan, N.J., Woodbury, Method of treating solid with high dynamic pressure,US3667911A,1972.
- [7] G. A. Adadurov, A. V. Baluev, O. N. Breusov, et al., Some properties of diamonds produced by an explosive method, *Izv. Akad.Nauk SSSR, Ser. Neorg. Mater.*, 1977.13,(4): p.649–653.
- [8] V. N. Drobyshev, Detonation synthesis of superhard materials, *Combust., Expl., Shock Waves*, 1983.19(5):p.677–678.
- [9] V.F. Tatsii, A.V. Bochko, G.S. Oleinik. Structure and Properties of Dalan Detonation Diamond. *Combustion Explosion and Shock Wave*. 2009.45(1):p.95-103.
- [10] A. M. Staver, N.V. Gubareva, A.I. Lyamkin, and E.A. Petrov. Ultradiapersed diamond powers produced with the use of explosive energy. *Fizika Goreniya i Vzryva*, 1984.20(5):p. 100-104.

- [11] A. I. Lyamkin, E.A.Petrove, A. P. Ershove, G. V. Sakovich, A. M. Staver, and V. M. Titov. Production of diamond from explosives. Dokl. Acad. Nauk USSR, 1988.302(3):p.611-613.
- [12] N. R. Greiner, D. S. Phillips, J. D. Johnson, F. Volk. Diamonds in detonation soot. Nature, 1988.333 (6172):p. 440-442.